

CHUKA



UNIVERSITY

UNIVERSITY EXAMINATIONS

EXAMINATION FOR THE AWARD OF BACHELOR OF SCIENCE IN ENGINEERING PHYSICS

EPHY 453 ELECTRONICS NETWORKS LABORATORY

STREAMS: BSC EENG

TIME:2 HOURS

DAY/DATE: TUESDAY 17/12/2024

8.30 A.M. –10.30 A.M.

INSTRUCTIONS

ANSWER QUESTION ONE AND ANY OTHER TWO QUESTIONS

QUESTION ONE (30 MARKS)

THEORY

The two basic laws of electricity that are most useful in analyzing circuits are Kirchhoff's laws for current and voltage. Kirchhoff's Current Law (The Junction Rule) states that at any junction (node) of a circuit, the algebraic sum of all the currents is zero (sum of the currents entering the junction equals the sum of the currents leaving the junction). In other words, electric charge is conserved. $\sum I_{in} = \sum I_{out}$

Kirchhoff's Voltage Law (The Loop Rule) states that around any closed loop or path in a circuit, the algebraic sum of all electric potential differences is equal to zero. $\sum V_i = 0$

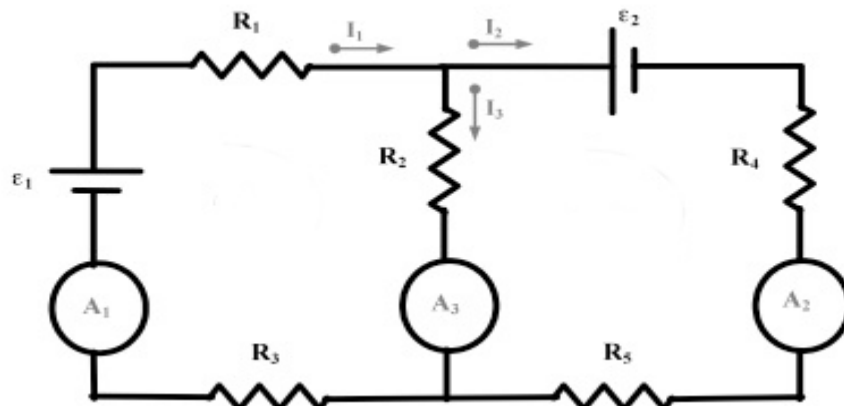

Figure .1

EPHY 453

$R_1 = 10 \Omega$ Resistor, $R_2 = 12 \Omega$ Resistor, $R_3 = 15 \Omega$ Resistor, $R_4 = 18 \Omega$ Resistor, $R_5 = 22 \Omega$ Resistor
 $\epsilon_1 = 12\text{V}$ and $\epsilon_2 = 18\text{V}$

- a) Use Kirchoff's Current Law and Voltage Law to solve for the theoretical currents, i_1 , i_2 , and i_3 (6 marks)
- b) Use Kirchoff's Voltage Law to find the missing voltage differences in circuits. In figures 2, 3 and figure 4 (6 marks)

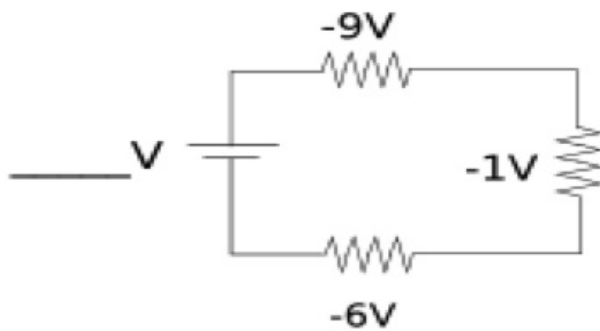

Figure. 2



Figure. 3

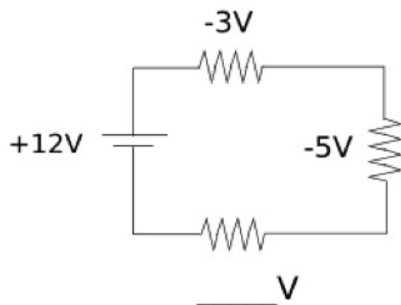

Figure. 4

- c) The ammeter shown in Figure 5 reads 2.00 A. Find I_1 , I_2 , and ϵ (4 marks)

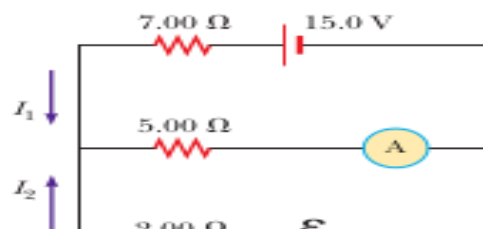

Figure. 5

- d) In the circuit of Figure P18.18, the current I_1 is 3.0 A while the values of \mathcal{E} and R are unknown. What are the currents I_2 and I_3 ? (4 marks)

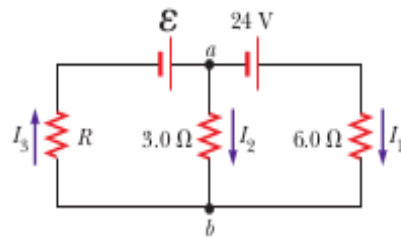

Figure. 6

- e) List six common electronics Laboratory Instruments and state their uses (6 marks)
- f) For each, use Kirchhoff's Current Law to fill in the value of the missing current. [Note each sign (+/-) and direction] (4 marks)

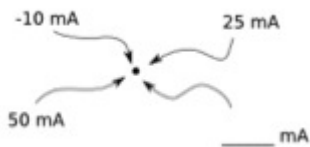

Figure. 7A

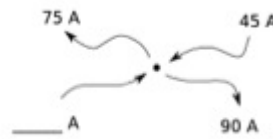

Figure. 7b

QUESTION TWO (20 MARKS)

- a. Name the factor which is required for voltage regulation to keep diode in the breakdown region. (1 mark)
- b. A voltage regulator is an electronic circuit that provides a stable DC voltage independent of the load current, temperature and AC line voltage variations. A zener diode of break down V_Z is reverse connected to an input voltage source V_1 across a load resistance R_L and a series resistor R_S . The voltage across the zener will remain steady at its break down voltage V_Z for

all the values of zener current I_Z as long as the current remains in the breakdown region. Hence a regulated Dc output voltage $V_0 = V_Z$ is obtained across R_L , whenever the input voltage remains within a minimum and maximum voltage. Basically there are two type of regulations such as:

Line Regulation: In this type of regulation, series resistance and load resistance are fixed, only input voltage is changing. Output voltage remains the same as long as the input voltage is maintained above a minimum value. Percentage Line regulation = $(\Delta V_{OUT} / \Delta V_{IN}) \times 100$

Load Regulation: In this type of regulation, input voltage is fixed and the load resistance is varying. Output volt remains same, as long as the load resistance is maintained above a minimum value. Percentage Load regulation = $(V_{NL} - V_{FL} / V_{FL}) \times 100$

Components required: Zener diode, resistor, rheostat, voltmeter, ammeter, DC source.
Software used: Proteus.

Circuit diagrams: Zener diode as line regulator

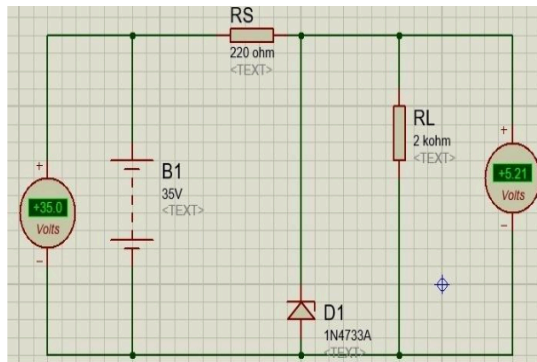

Figure

Circuit diagrams: Zener diode as load regulator

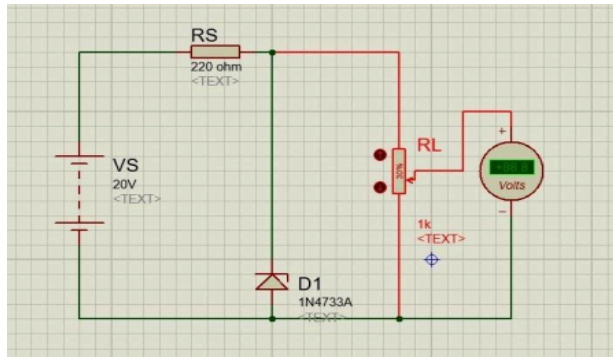

8

Figure.9

Observation Table 1

Zener Line Regulation

$R_s = 220 \text{ Ohms}$ Zener Voltage (V_z) = 5.1 V
 $R_L = 2 \text{ k}\Omega$

Load Line Regulation

$R_s = 220 \text{ Ohms}$ Zener Voltage (V_z) = 5.1 V, Voltage supply (V_s) = 20V, no Load Voltage (V_{NL}) = 5.14V

SL No	Unregulated Supply Voltage (V_s) Volt	Regulated Output Voltage (V_o) Volt	%Voltage Regulation ($V_o / V_s \times 100$)	SL No.	Load Resistance (R_l) Ohms	Regulated Output Voltage (V_{FL}) Volt	%Voltage Regulation ($(V_{NL} - V_{FL}) / V_{FL} \times 100$)
1	1	0		1	1000	5.11	

EPHY 453

2	2	1	2	950	4.85
3	3	1.5	3	900	4.6
4	4	2	4	850	4.34
5	5	2.5	5	800	4.09
6	6	3	6	750	3.83
7	7	3.5	7	700	3.58
8	8	4	8	650	3.32
9	9	4.5	9	600	3.03
10	10	4.94	10	550	2.81
11	11	5	11	500	2.55
12	12	5.03	12	450	2.3
13	13	5.04	13	400	2.04
14	14	5.05	14	350	1.79
15	16	5.07	15	300	1.53
16	18	5.09			
17	20	5.1			
18	25	5.1			
19	30	5.1			
20	35	5.2			

- c. Define a Zener diode (2 marks)
- d. Calculate the percentage line Voltage Regulation $(V_o/V_s) \times 100$ and percentage load Voltage Regulation $(V_{NL} - V_{FL} / V_{FL}) \times 100$ (7 marks)
- e. Draw a graph of output Voltage (V_o) versus supply Voltage (V_s) (4 marks)
- f. Draw a graph of output Voltage (V_o) versus Load Resistance (R_L) (4 marks)
- g. Advantages of Zener Diode Voltage Regulation (2 marks)

QUESTION THREE (20 MARKS)

To study and verify the Truth Tables of AND, OR, NOT, NAND, NOR, EXOR logic gates.

Components: IC 7400, 7402, 7404, 7408, 7432, 7486

Apparatus: Prototyping board (breadboard), DC Power Supply, Connecting Wires

Theory:

AND, AND, OR and NOT gates are basic gates. XOR and XNOR are universal gates. Basically logic gates are electronic circuits because they are made up of number of electronic devices and components. Inputs and outputs of logic gates can occur only in two levels. These two levels are term HIGH and LOW, or TRUE and FALSE, or ON AND off, OR SIMPLY 1 AND 0. A table which lists all possible combinations of input variables and the corresponding outputs is called a „truth table“. It shows how the logic circuit“s output responds to various combinations of logic levels at the inputs.

AND GATE:

An AND gate has two or more inputs but only one output. The output assumes the logic 1 state only when each one of its inputs is at logic 1 state. The output assumes logic 0 state even if one of its input is at logic 0 state. AND gate is also called an „all or nothing“ gate. The logic symbol & truth table of two input AND gate are shown in figure 1.a & 1.b respectively. The symbol for AND operation is „“. With input variables A & B the Boolean expression for output can be written as; $X = A.B$

NOR GATE

NOR gate is universal gate. It can perform all the basic logic function. NOR means NOT OR that is, OR output is NOTed.so NOR gate is combination of an OR gate and a NOT gate. With input variables A & B the Boolean expression for output can be written as;

$$X = \overline{A + B}$$

An X-OR gate is a two input, one output logic circuit, whose output assumes a logic 1 state when one and only one of its two inputs assumes a logic 1 state. With input variables A & B the Boolean expression for output can be written as; $X = A \oplus B$

- a) Draw a Logic symbol:for the AND GATE (2 marks)
- b) Fill the truth table 2 (2 marks)

Truth Table 2

INPUT		OUTPUT
A	B	X
0	0	
0	1	
1	0	
1	1	

- c) Fill the Table below: (12 marks)
- d) Observation in Table3: LED ON (RED light): Logic 1 LED OFF (Green Light): Logic 0
Input variables: A, B Output variable: Y

Sr. No	Input(A) LED	Input(B) LED	Output (OR) $\overline{Y} = A$	Output (AND) $Y = AB$	Output (OR) $Y = A + B$	Output (NOR) $\overline{Y} = \overline{A + B}$	Output (XOR) $Y = A \oplus B$
1	0	0					
2	0	1					
3	1	0					
4	1	1					

- e) What is the difference between the ordinary algebra and Boolean algebra? (4 marks)

QUESTION FOUR (20 MARKS)

AIM: To verify the Kirchhoff's voltage law and Kirchhoff's current law for the given circuit

PROCEDURE: Kirchhoff's Voltage law:

Series Circuit:

In this lab experiment we had to use ohmmeter to measure and record the value of the resistance R_1 and R_2 in table 4. Then after recording the values we were asked to connect it to the circuit as shown in figure 3. As the circuit the circuit was formed, the next necessary step was to switch on the DC power supply. For the values of R_1 and R_2 , we had to record the values of V_T , V_1 , V_2 and I in the table 4. Then we were asked to check whether the $R_T = R_1 + R_2$. Also we checked $V_T = V_1 + V_2$.

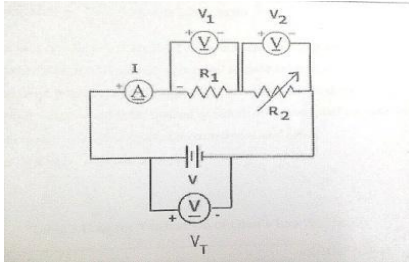

Figure 10

Parallel Circuit

An was used Ohmmeter and measured and recorded the value of Resistance R_1 and R_2 in the table 5. Then we connected the circuit as shown in Fig.4. For the given values of R_1 and R_2 we recorded the reading for V_T , V_1 , V_2 , I_1 , I_2 and I in the table 5.

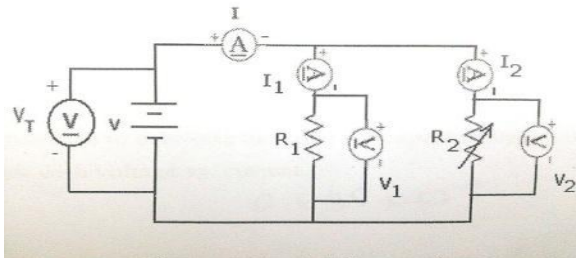

Figure 11

Table 4: Study of Resistor in series and Kirchhoff's Current Law:

R_1 (Ω)	R_2 (Ω)	V_1 (V)	V_2 (V)	I (A)	V_T	$R_T = V_T / I$	$V_1 + V_2$

4700	3000	6.15	3.90	0.0012 9	10.07		
------	------	------	------	-------------	-------	--	--

Table 5: Study of Resistors in Parallel and Kirchoff's Voltage Law:

R1 (Ω)	R2 (Ω)	V1 (V)	V2 (V)	V _T	I1 (A)	I2 (A)	I (A)	R _T =V _T /I	I ₁ +I ₂
4700	3000	10.05	10.05	10.05	0.0021	0.0033	0.005 9		

- a) State Kirchoff's Voltage law and Kirchoff's current law (2marks)
- b) For Series Circuit complete the table and verify the Kirchoff's Voltage Law (4 marks)
- c) Calculate the Theoretical value R_T (2 marks)
- d) For Series Circuit complete the table and verify the Kirchoff's current Law (4marks)
- e) Calculate the Theoretical value R_T (2 mark)

- f) Find V₁ , I₂ , and I₃ in Figure below. (6marks)

