

CHUKA

UNIVERSITY



UNIVERSITY EXAMINATIONS

**FIRST YEAR EXAMINATION FOR THE AWARD OF DEGREE OF
BACHELOR OF SCIENCE IN BIOMEDICAL TECHNOLOGY, BACHELOR OF
SCIENCE IN FOOD SCIENCE AND TECHNOLOGY AND BACHELOR OF
SCIENCE IN HORTICULTURE**

PHYS 111: GENERAL PHYSICS

STREAMS: Bsc.(BMED, FOST & HORT)

TIME: 2 HOURS

DAY/DATE: FRIDAY 12/4/2024

2.30P.M. – 4.30 P.M.

DAY/DATE:TIME

INSTRUCTIONS: Answer question ONE and any other TWO questions

QUESTION ONE (30MARKS)

- a) The current in a wire varies with time according to the relation $I = 3 + 2t$
- i. How many coulombs of charge pass a cross-section of the wire in the time interval between $t = 0$ and $t = 4.0$? [3marks]
 - ii. What constant current would transport the same charge in the same time interval? [2marks]
- b) Check whether the equation below is dimensionally correct.
- $$P = h\rho g \quad [3 \text{ Marks}]$$
- c) Give the necessary conditions for total internal reflection. [2 marks]
- d) A ray of light travelling through a liquid of absolute refractive index 1.2 is incident on the plane surface of a glass block at an angle 25° . Calculate the angle of refraction in the glass if it has an absolute refractive index 1.5 [4marks]
- e) Differentiate between accuracy and precision in a measurement. [2 marks]
- f) From the Newton's second law, show that

$$F=ma$$

when F is resistant force, m is mass and a is acceleration.

[4marks]

- g) Derive the equations of linear motion [4 marks]
- h) A charge of quantity 5×10^{-6} C flows through a conductor in 6 seconds, calculate the amount of current in the conductor [2marks]
- i) An object is placed 20cm in front of a concave mirror of focal length 15cm, determine the position and nature of image formed. [4 marks]

QUESTION TWO (20 MARKS)

- a) State the Fermat's principle [1marks]
- b) Using Fermat's principle and well labelled diagram, show that
- i. $n_1 \sin \theta_1 = n_2 \sin \theta_2$ (snells law) [5 Marks]
 - ii. $\theta_1 = \theta_2$ (reflection law) [5 Marks]
- c) The reflecting surfaces of two intersecting flat mirrors are at an angle θ ($0^\circ < \theta < 90^\circ$), as shown in Figure 1. For a light ray that strikes the horizontal mirror, show that the emerging ray will intersect the incident ray at an angle $\beta = 180^\circ - 2\theta$. [5 Marks]

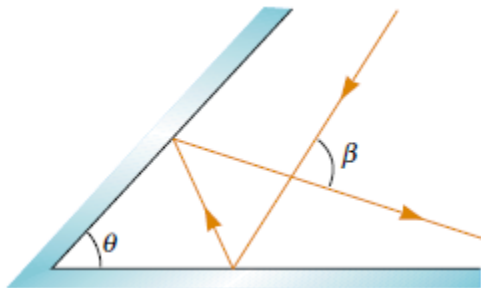
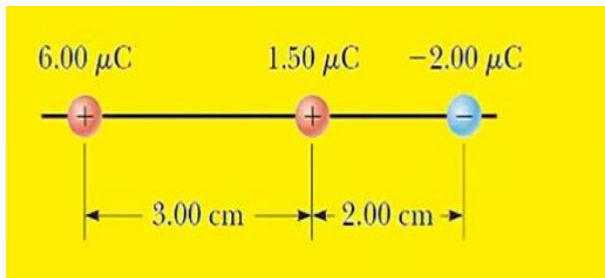

Figure 1

- d) Explain the dual nature of light and hence state one experiment which each nature is depicted [4 Marks]

QUESTION THREE (20MARKS)

- a) State the law of conservation of momentum [2marks]
- b) Calculate the magnitude and direction of Coulomb force on each of the three charges shown in the figure below. [6 Marks]



- c) A bullet is projected at a horizontal velocity of 150m/s from a building 60m high.
Calculate;
- Time it takes to hit the ground [4marks]
 - The horizontal distance from the foot of the building to where it hits the ground [4marks]

- d) A bus accelerates at 2m/s^2 in 25 minutes from rest then maintains the velocity attained for the next 40 minutes. It decelerates to rest at 4m/s^2 . calculate the total distance covered by the track [4 marks]

QUESTION FOUR (20MARKS)

- Using well labelled diagram explain the production of X-Rays [5 Marks]
- There are different ways in which X-Rays interact with matter, Explain how these interactions are related to diagnostic radiology [4 Marks]
- Calculate the percentage of X-ray beam absorbed by a bone of thickness 3cm and μ/ρ of the bone to that X-ray energy is $0.2\text{cm}^2/\text{g}$, and ρ of the bone is 1.9g/cm^3 [3Marks]
- Explain three medical applications of radiation [6 Marks]
- Name three types of radiation can be emitted by a radioactive substance [2Marks]

QUESTION FIVE (20MARKS)

- State Kirchoff's circuital laws [2marks]
- Can the circuit shown in Figure 2 be reduced to a single resistor connected to a battery? Explain. Calculate the currents I_1 , I_2 , and I_3 . [7marks]

PHYS 111

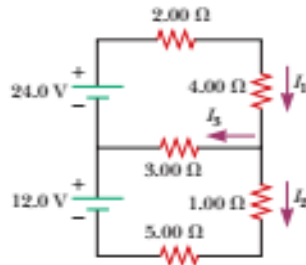

Figure 2

- c) A resistor of unknown resistance and $25\ \Omega$ resistor in parallel are connected across a $140\ \text{V}$ battery in such a way that $18\ \text{A}$ current flows. What is the value of unknown resistor?

[5marks]

- d) Consider the circuit shown in Figure 3. Find the voltage across the $3.00\ \Omega$ resistor and the current in the $3.00\ \Omega$ resistor.

[6 Marks]

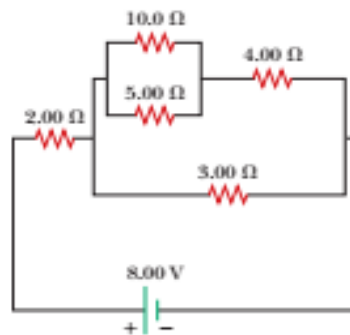

Figure 3