



[library@chuka.ac.ke](mailto:library@chuka.ac.ke); [www.chuka.ac.ke](http://www.chuka.ac.ke)

## ASSESSMENT OF TRACE ELEMENTS CONCENTRATION IN ENVIRONMENTAL AND GEOLOGICAL SAMPLES IN SELECTED AREAS OF IGAMBANG'OMBE CONSTITUENCY IN, THARAKA-NITHI COUNTY, KENYA

Chuka University, P. O. Box 109-60400, Chuka. Email: [mmutie@chuka.ac.ke](mailto:mmutie@chuka.ac.ke), [snjogu@chuka.ac.ke](mailto:snjogu@chuka.ac.ke)

### Citation

Mutie, M.M., Njogu, S., Amanai, J.O. and Murigi, F.N(2015). Assessment of trace elements concentration in environmental and geological samples in selected areas of Igambang'ombe constituency in, Tharaka-Nithi county, Kenya In: Isutsa, D.K. and Githae, E.W. Proceedings of the Second Chuka University International Research Conference held in Chuka University, Chuka, Kenya from 28<sup>th</sup> to 30<sup>th</sup> October, 2015. 194-2002 pp.

### ABSTRACT

Concentrations of trace elements: cadmium, lead, copper and chromium were determined in soil and rock samples using Fourier Transform Infrared (FTIR) spectrometric technique. The elements were identified and quantified to determine their levels in soils and rocks, using the FTIR spectrometer. The trace elements contents were compared with the permissible limits of the World Health Organization. Concentrations of trace elements in rock samples had significant variability and ranged from 12.2 to 18.1  $\mu\text{g/g}$  for Copper (Cu), 40.9 to 50.1  $\mu\text{g/g}$  for zinc (Zn), 21.3 to 26.4  $\mu\text{g/g}$  for lead (Pb) and 2.45 to 3.6  $\mu\text{g/g}$  for Cadmium (Cd). In soil samples the range was 27.2 to 30.0  $\mu\text{g/g}$  for Cu, 30.4 to 34.9  $\mu\text{g/g}$  for Pb, 0.86 to 2.6  $\mu\text{g/g}$  for Cd and 19.5 to 27.0  $\mu\text{g/g}$  for Cr. The concentration levels were low, except for cadmium which had a range slightly above the permissible maximum of 3.0  $\mu\text{g/g}$ . Proper use of fertilizers accredited and approved by the Kenya Bureau of Standards should be enforced so as to maintain the safe levels of the trace elements. Environmental surveillance should be done regularly to ascertain contamination levels to help minimize environmental pollution.

**Keywords:** FTIR, Contamination, Permissible Limits, Environmental Pollution

### INTRODUCTION

Trace elements constitute a natural component of the earth crust [20]. The soil, a main part of the terrestrial ecosystem, is a habitat for a great number of organisms but at the same time, it is perhaps the most endangered component of our environment. Trace elements may come from natural sources, leached from rocks and soils according to their geochemical mobility or come from anthropogenic sources, as the result of human land occupation and industrial pollution [5, 11, 17, 18 and 19]. Among pollutants, trace elements have been the subject of particular attention because of their long-standing toxicity when exceeding specific

thresholds [11, 13,14and16]. Among the key issues in the environmental research on heavy metals is their mobility in the ecosystems and transfer in the food chains [20, 21, and 22] . Uncontrolled development in industry, agriculture and urbanization accelerates the input of heavy metals into the environment in many part of the world [8 and 9]. Many scientific activities have been devoted to the determination of sources, types, and degree of heavy metal pollution in soil [1, 2, 5 and 8]. An important background for this kind of work is knowledge on geochemical baseline concentrations of elements [15, 16]. The assessment of the concentration of heavy metals has not being exhaustive in terms of geographical coverage, the media and the parameters used. Little is reported on the human contamination by heavy metals particularly the local farmers' community, business and general public living in Igambang'ombe Constituency. Agricultural practices – for instance, the use of fertilizers and pesticides for the control of pests in the cultivation of coffee, tea, and other activities such as industry as well as growth of the human population have increased the discharge of waste into the environment, rendering it environmentally unstable [9, 10 and 12]. Research is hence required in Igambang'ombe Constituency to stimulate information and illustrative data for the appropriate health and environmental authorities, as well as create cognizance among the general community about the emblematic levels of trace elements and heavy metals in the surroundings

## **MATERIALS AND METHODS**

### **Study Location**

Tharaka Nithi County is one of the 47 counties in Kenya, located on the eastern part of Mount Kenya and covering an area of 2609.5km<sup>2</sup>. It is subdivided into three administrative constituencies; Chuka Igambang'ombe, Maara and Tharaka. This study was carried out in selected areas, of Chuka Igambang'ombe Constituency, Tharaka Nithi County, Kenya. The constituency has a population of 128,107 people and covering an area of 431.2Km<sup>2</sup>. Fourier transform infrared spectroscopy is mostly preferred over filter methods IR spectral analysis due to reasons such as its non-destructive nature, high sensitivity, high precision and simplicity of operation. Energy dispersive X-ray spectroscopy technique(EDXRF) was used to confirm results by FTIR technique.

### **Sampling**

Top soil samples were collected from 10 separate locations; CH 01, CH02, CH03, CH04, CH05 CH06, CH07, CH08, CH09 and CH010 within the Chuka Igambang'ombe constituency .Four rock samples were collected. Figure 1 shows the sampling points .The samples were taken at depths of 10cm -15cm, at selected sites in the constituency. The samples were collected with a hand auger (a stainless steel crew) and hand spade and were placed in a clean polyethylene bags to avoid contamination. The samples were oven dried at 80°C for 24 hours to prevent volatilization of certain trace elements which occurs above those temperatures. They were then finely ground and passed through a 2 µm sieve well labelled and stored in plastic vials [7]. Ground and sieved samples were pelleted using the Carver Hydraulic Press (Carver, Inc.). 0.001 g of each sample were mixed with 0.1g of KBr salt, and pressed for 4 minutes. Three pellets were made for each soil sample with a pellet thickness of 1.0 mm. Pellets were scanned in the mid-IR on FT-IR Spectrometer equipped with a Universal ATR. Pellets were scanned from 4000 to 400 cm<sup>-1</sup> at 1 cm<sup>-1</sup> resolution with 10 scans per spectrum.

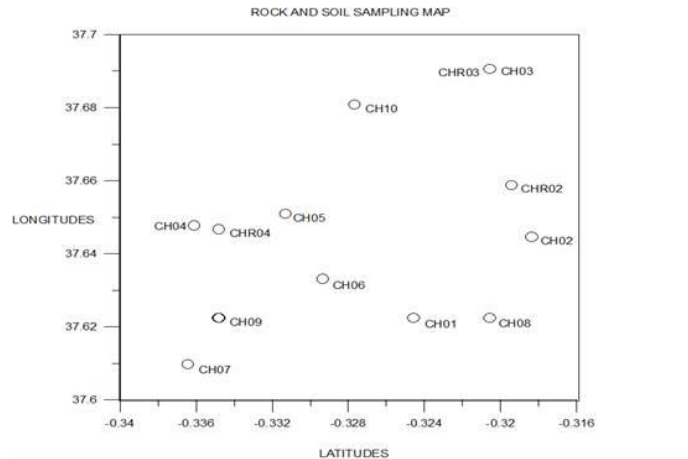

**Figure 1:** Sampling points in Igambang’ombe Constituency

**Table 1:** List of soil and rock samples analyzed for elemental concentration

Sample	Type	No. of samples
Soil	Loamy, murram, volcanic	10
Rock	Volcanic	4

### Fourier Transform Infrared Spectrophotometer (FTIR) equipment

The technique used by this instrument is the Fourier Transform Infrared (FTIR) Spectroscopic technique. The technique is also called “finger print”- this is because it identifies the various compounds basing on infrared interactions which are unique for any given compound. The infrared interacts with the compound bonds causing stretching and bending. The bending can be rocking, wagging, twizzling or twists depending on the interaction. The flow diagram below shows the working of the instrument. ). Laboratory analysis was conducted using Transform Infrared (FTIR) Spectroscopic technique for qualitative analysis followed by analysis by Energy dispersive X-ray florescence for quantitative analysis.

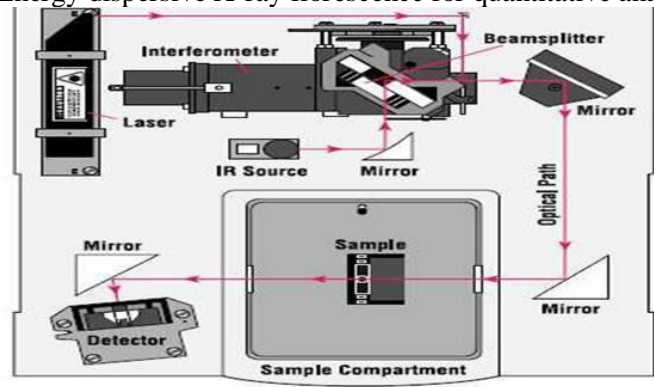

**Figure 2:** diagram of FTIR spectrometer

### Data Analysis

The wavelengths from the graph were compared with those of various trace elements from table to determine their presence. The data obtained was analyzed using Beer Lamberts law which relates the attenuation of light to the properties of the material through which the light is travelling and is given by:

$$A = \log \left( \frac{I_0}{I_t} \right) = \Sigma bc \quad (1)$$

Where:  $\Sigma$  is the molar absorption constant.  
 $b$  is path length constant equal to 1cm.

c is the concentration of the compound.

Concentration of the element was determined by the formula:

$C = c \times M$ , Where: M is the molar mass of the element and C is the concentration of the element.

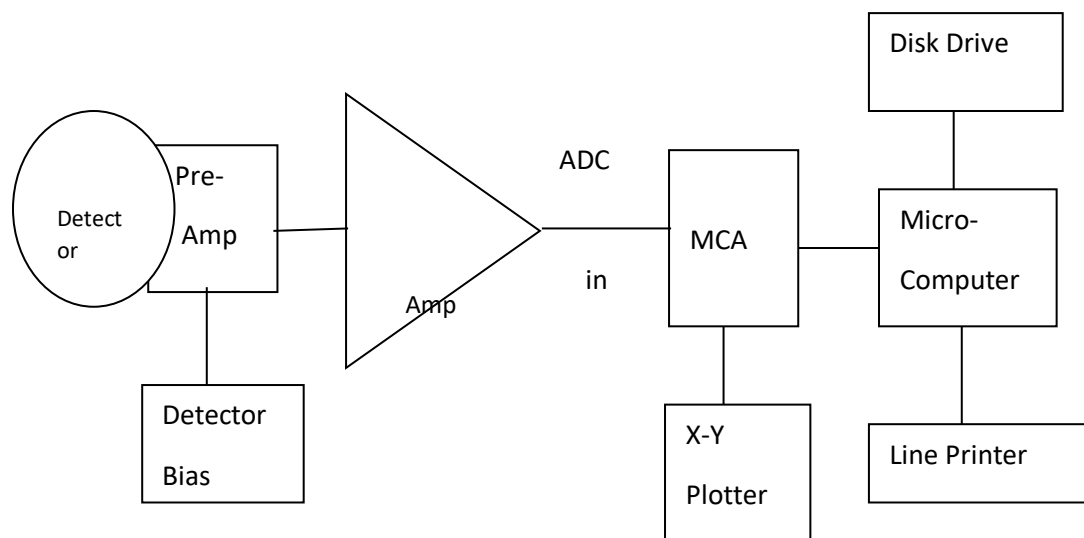

**Figure 3:** Schematic diagram of the EDXRF spectrometer

X-ray spectra analyses and quantification were done using quantitative X-ray analysis system IAEA-QXAS software and (AXIL), Analysis of X-ray Spectra by Iterative Least squares fitting [6]. Canberra S 100 was used for data acquisition. The energies of the photo peaks present on the X-ray spectrum were determined and compared with tables of X-ray energies to identify the elements present in the sample. The emission – transmission technique [4] was used for the calculation of the X-ray absorption correction in the soil and rock samples. Dissolved trace metals (Mn, Fe, Zr, Rb, Sr, Zn and Pb) were determined by an optimized method of X-ray fluorescence (XRF) spectroscopy after preconcentration of their samples by ammonium pyrrolidine dithio-carbamate (APDC) on cellulose filters. The peak areas were evaluated and elemental concentration determined using software [6].

## RESULTS AND DISCUSSION

### Soil Samples

The metals of interest found in the soil samples are Iron (Fe), zinc (Zn), Manganese (Mn), lead (Pb), Strontium (Sr) and Rubidium (Rb). Table 2 shows the concentration levels of elements analysed in the soil samples from selected areas of Igambang'ombe constituency. The soil samples were found to contain minimal concentrations of heavy metals. The soil concentration of zinc ranged from 112 µg/g to 209 µg/g where the levels were far below the 300 µg/g maximum limit recommended by WHO. The concentration of lead ranged from 16 µg/g to 48 µg/g against the 100 µg/g recommended level. Figure 4 shows the lead (Pb) concentrations in soil samples while figure 5 shows the comparison of Zinc and Strontium concentration in soil samples. The concentration of strontium ranged from 80 µg/g to 351 µg/g against the 300 µg/g recommended limit. Samples from Ndagani market (CH 05) had strontium levels above the WHO recommended limit of 300 µg/g, this could be due improper dumping of refuse, uncontrolled land occupation and urbanization. The soil concentration of Iron ranged from 4960 µg/g to 20100 µg/g against the 50 000 µg/g recommended limit. Manganese concentration levels ranged from 224 µg/g to 1060 µg/g against the 2000 µg/g recommended limit. The concentrations of rubidium ranged from 28 µg/g to 110 µg/g. Samples from Ndagani (Ch05) had values above the recommended limit of 100 µg/g. From the analysis above, it was observed that the heavy metal concentrations in most soil samples were far below

the recommended limits except for Strontium and rubidium in CH05. Therefore, contaminations of soils in the constituency were found to be minimal as per the WHO standards.

**Table 2:** Concentration levels of heavy metals in different soils ( $\mu\text{g/g}$ )

Soil sample	Fe	Mn	Sr	Zn	Pb	Rb
CH 01	9940	250	129	168	21	30
CH 02	12420	929	86	198	16	48
CH 03	20100	1060	181	141	36	65
CH 04	12410	360	155	209	48	28
CH 05	4960	224	351	112	21	110
CH 06	8620	264	87	186	19	46
CH 07	9210	362	80	126	25	37
CH 08	11230	422	106	156	32	62
CH 09	10600	413	121	132	24	45
CH 10	18640	612	87	152	36	53
Recommended maximum levels (WHO)	50000	2000	300	300	100	100

### Rock samples

The metals of interest found in the soil samples are Iron (Fe), zinc (Zn), Manganese (Mn), lead (Pb), Strontium (Sr) and Rubidium (Rb). Concentrations levels of heavy metals in rocks is shown in table 3. The concentration ranged between 3920 to 7320  $\mu\text{g/g}$  for iron (Fe) which are below the recommended limit of 50000  $\mu\text{g/g}$ . The concentration levels of for Zinc (Zn) ranged from 92 to 128  $\mu\text{g/g}$ . lead (Pb) levels varied from 21 to 33  $\mu\text{g/g}$  which are far below the world's permissible value of 100  $\mu\text{g/g}$ . Manganese (Mn), levels ranged from 184 to 326  $\mu\text{g/g}$  while Strontium (Sr) concentration varied from 864 to 1351  $\mu\text{g/g}$ . Strontium levels in all rock samples were above the maximum recommended limit of 300  $\mu\text{g/g}$ . Rubidium (Rb) levels ranged from 112 to 128  $\mu\text{g/g}$  which are above the recommended limit of 100  $\mu\text{g/g}$ .

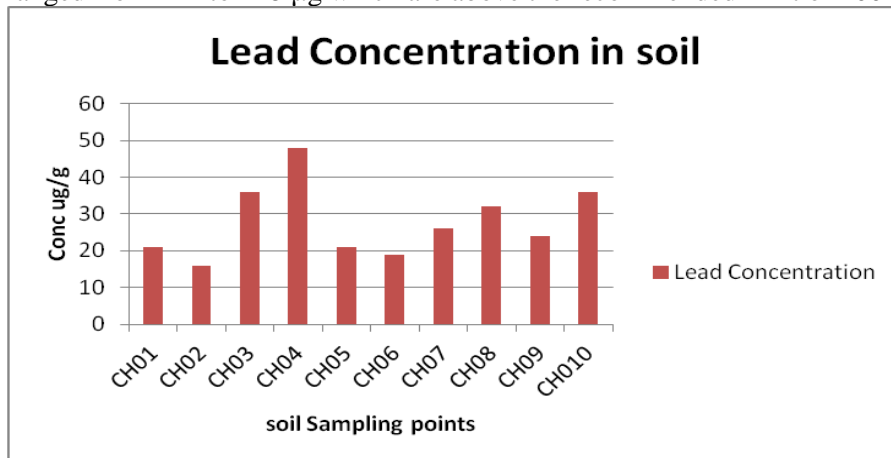

**Figure 4:** A graph of lead concentration against soil sampling points

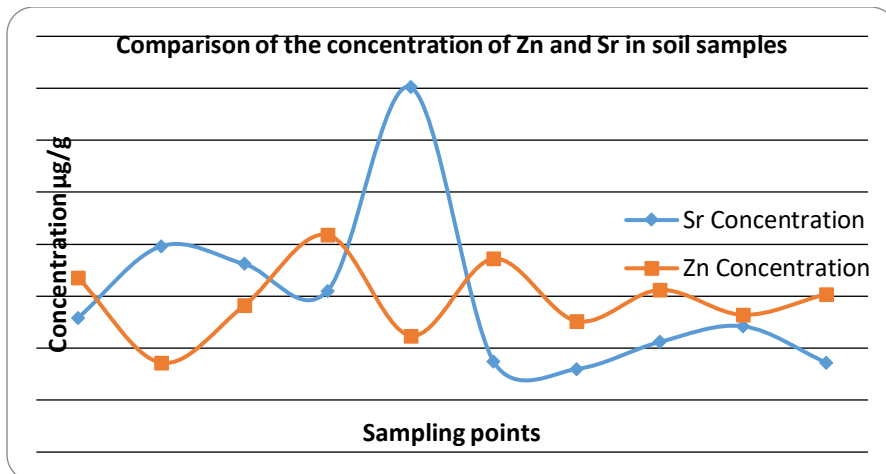
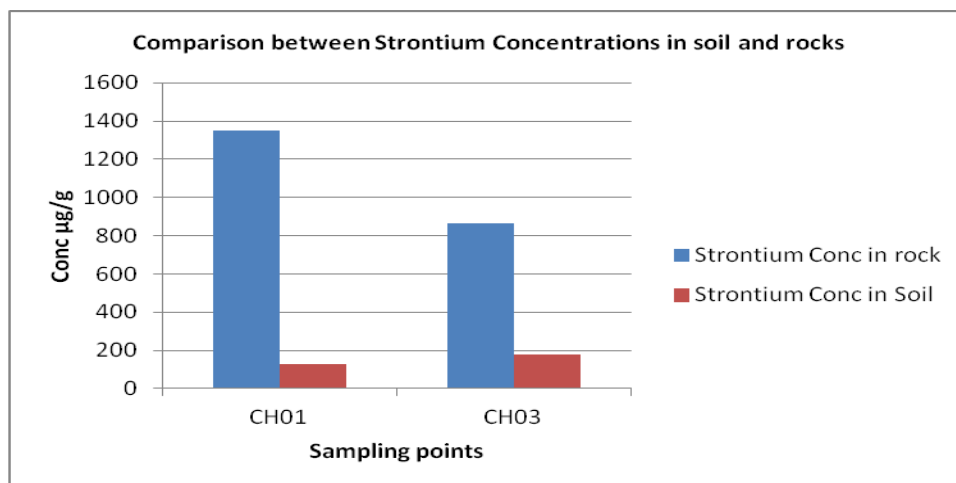

**Figure 5:** A graph showing comparison of zinc and strontium concentration in soil samples

Comparing to the Maximum permissible limits of heavy metals by WHO, the concentration levels of Fe, Zn, Mn, and Pb were found to be low but concentration levels of strontium and rubidium in all rock sampling sites were found to be higher than the WHO recommended limit of 300 µg/g and 100 µg/g respectively. The average concentrations of the elements is shown in table 4. Rock samples had higher concentration of Strontium than soil samples from the same sampling points as shown by figure 6. Soil samples had higher concentration of lead than rock samples from the same sampling points as shown by figure 7. Comparing the average concentration of the heavy metals and trace elements in soils and rocks, it was found that the soils had higher concentrations of Fe, Zn, Cu and Rb while rock samples had higher concentrations of Ca, Ti, Sr and K as shown in the figures 8 and 9.

**Table 3:** Concentration levels of heavy metals in different rocks (µg/g)

Rock sample	Fe	Mn	Zn	Sr	Rb	Pb
CHR 01	3920	220	116	1351	112	23
CHR 02	4620	261	98	1120	121	21
CHR 03	6940	184	92	864	118	29
CHR 04	7320	326	128	928	128	33
Recommended maximum levels(WHO)	50000	2000	300	300	100	100



**Figure 6:** A graph showing comparison of Strontium concentration in soil and rock sampling points

**Table 4:** Average Concentration levels of heavy metals in soil and rocks samples ( $\mu\text{g/g}$ )

Element	Soil	Rock
K	19900	20000
Ca	16400	25400
Ti	5700	8000
Fe	40500	27500
Cu	80.6	49.4
Zn	87.1	75.1
Rb	74.4	36.8
Sr	227.1	241.6
Zr	529.4	231.6
Mn	790.7	775.9
Pb	20.9	11.4

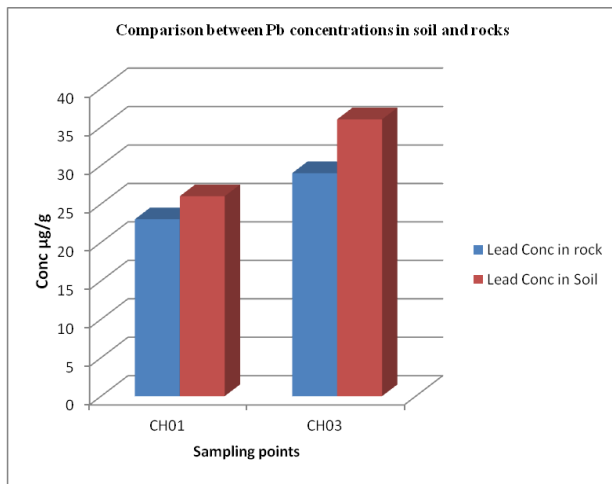

**Figure 7:** A graph showing comparison of lead concentration in rock and soil sampling points

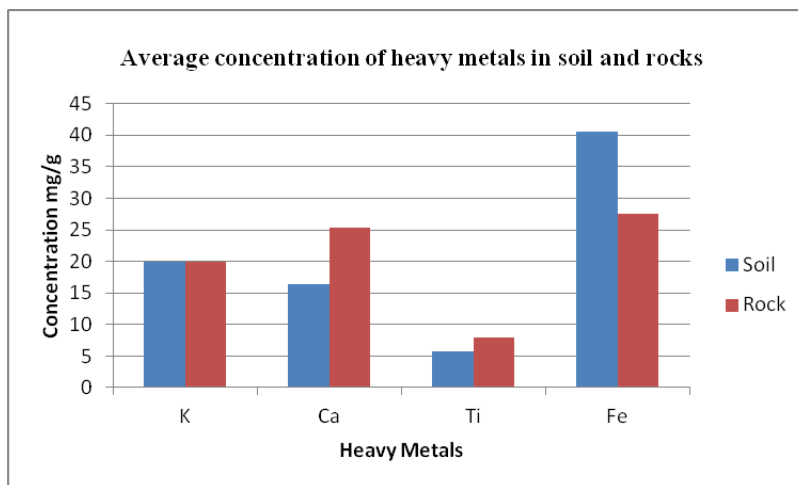

**Figure 8:** A graph showing average concentration of major elements in rock and soil samples

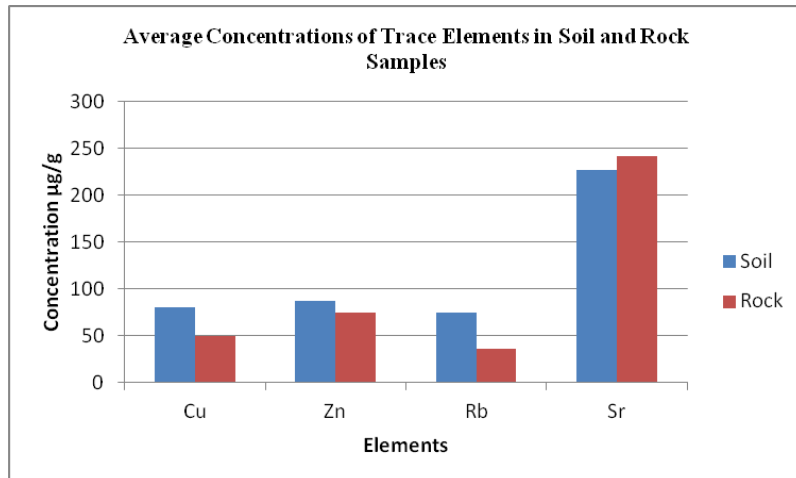

**Figure 9:** A graph showing average concentration of Trace elements in rock and soil samples

## CONCLUSION

The results revealed that the samples from the agricultural soils in the area studied had minimal contents of heavy metals (Fe, Mn, Zn, Sr, Rb and Pb) capable of polluting the environment. This implies that the soils in Igambang'ombe Constituency are suitable for agricultural purposes, and crops grown on such soils may not pose health risks to the local community. However elevated levels of strontium were found in all rock samples and one soil sample (CH 05) above the recommended limit of 300 µg/g. Elevated levels of rubidium were found in the rock and soil samples CHR01, CHR02, CHR03, CHR04 and CH05 above the recommended limit of 100 µg/g. Environmental authorities will use the findings of this study to control human activities like quarry activities, fertilizer application and industrial waste dumping that cause serious environmental pollution. Data obtained will form background for further studies on heavy and trace metal concentrations in the environment.

## RECOMMENDATIONS

1. That occasional environmental surveillance is carried out in all parts of the county to ascertain contamination levels. This will help minimize environmental pollution.
2. That the County Government should set in place certain monitoring processes and empower NEMA and other relevant institutions such as the Ministry of Local Governments that handle solid waste disposal management at the municipal levels, to assess solid waste disposal practices and enact penalties to defaulters of such regulations.
3. That the local community be enlightened on proper use of fertilizers accredited and approved by the Kenya Bureau of Standards
4. Enforcement of environmental legislation -It is of great importance when developing a sustainable use of natural resources. One way to enforce legislation is by applying relevant environmental standards and Environmental restoration orders eg. Reafforestation.

## ACKNOWLEDGEMENT

The authors would like to thank Chuka University and University of Nairobi for Providing equipment and materials for this research.

## REFERENCES

- Benko, V., Cikrt, M. and Lener, J. 1995. Toxic metals in the environment. Prague: Grada; 1995:282.  
 Chow, T.J. 1970. Lead accumulation in road side soil and grass. Nature, 225: 295-296.  
 Das, J. 2003. Geochemistry of trace elements in the ground water of Cuttack city in India. Water, Air, and Soil Pollut. 147, 129-140.

- De, V. and Bakker. 1998. Manual for calculating critical loads of heavy metals for terrestrial ecosystem: Guidelines for critical limits, calculation methods and input data TNO Institute of Environmental Sciences, Energy Research and Process Innovation. Den Helder, The Netherlands. 144pp
- Giauque, R.D., Goulding, F.S., Jacklevic, J.M. and Pehl, R.H. 1973. Trace element determination with semi-conductor detector x-ray spectrometer. *Analytical Chemistry* 45 pp 671-681.
- Gimeno-García, E., Andreu, V. and Boluda, R. 1996. Heavy metals incidence in the application of inorganic fertilizers and pesticides to rice farming soil. *Environ. Pollut.* 92(1):19-25.
- IAEA. 1995. Quantitative x-ray analysis system (QXAS). Distributed by the International Atomic Energy Agency, IAEA. Vienna, Austria
- IAEA (International Atomic Energy Agency). 1997. Sampling, storage and sample preparations. procedures for x-ray fluorescence analysis of environmental samples. IAEA, Vienna, Austria
- Inoti, K.J., Kawaka, F., Orinda, G. and Okemo, P. 2012. Assessment of heavy metal concentrations in urban grown vegetables in Thika Town, Kenya. *African Journal of Food Science*, 6(3):41-46.
- Jepkoech, J.K., Simiyu, G.M. and Arusei, M. 2013. Selected heavy metals in water and sediments and their bioconcentrations in plant (*Polygonum pulchrum*) in River Sosiani, Uasin Gishu County, Kenya. *Journal of Environmental Protection*, 4, 96-802
- Kimani, N.G. 2007. Implications of the Dandora municipal dumping site in Nairobi, Kenya. environmental pollution and impacts on public health, Kenya: United Nations Environment Programme.
- McLaughlin, M. J.; Parker, D. R. and Clarke, J. M. 1999. Metals and micronutrients-food safety issues. *Field Crops Res.*, 60(1-2):143-163.
- Mielke, H.W. and Reagan, P.L. 1998. Soil is an important pathway of human lead exposure. *Environ. Health Perspect.* 106:217-229.
- Muiruri, J. M., Nyambaka, H. N. and Nawiri, M. P. 2013. Heavy metals in water and tilapia fish from Athi-Galana-Sabaki tributaries, Kenya. *International Food Research Journal*, 20 (2) 891-896.
- Neal, A.P. and Guilarte, T.R. 2012. Mechanisms of Heavy Metal Neurotoxicity: Lead and Manganese. *Journal of Drug Metabolism and Toxicology*, S5-002.
- Oyoo-Okoth, E., Admiraal, W., Osano, O., Ngure, V., Kraak, M.H. and Omutange, E.S. 2010. Monitoring exposure to heavy metals among children in Lake Victoria, Kenya: Environmental and fish matrix. *Journal of Ecotoxicology and Environmental Safety*, 73(7):1797-1803
- Premarathna, H.M.P.L., Hettiarachchi, G.M. and Indraratne, S. 2011. Trace metal concentration in crops and soils collected from intensively cultivated areas of Sri Lanka. *Pedologist*, 54(3):230-240.
- Qishlaq, A. and Moore, F. 2007. Statistical analysis of accumulation and sources of heavy metals occurrence in agricultural soils of Chock 122 River Banks, Shiraz, Iran. *American-Eurasian Journal of Agricultural and Environmental Science*, 2, 565-573.
- US Environmental Protection Agency. 1998. Sources of lead in soil: EPA 747-R-98-001a, US Environmental Protection Agency, Washington, DC.
- Tiller, K.G.; Oliver, D.P.; McLaughling, M.J. and Naidu, R., 1995. Managing cadmium contribution of agriculture land In: Iskanar, I.K. and Adriano, D. C. (eds.). *Remediation of soils contaminated by metals* Science and Technology Letters, Northwood, Middlesex.
- WHO. 1995. Trace elements in human nutrition and health. World Health Organization, Geneva, 1995.
- Wright, C.H. 1939. *Soil Analysis*. Thomas Murby and Co., London
- Xintaras, C. 1992. Analysis Paper: Impact of Lead-Contaminated Soil on Public Health. U.S. Department of Health and Human Services. Public Health Service Agency for Toxic Substances and Disease Registry. Atlanta, Georgia.

\*\*\*\*\*